

# Vacuum filter FC-series

The SiccaDania FC filters are especially suitable for washing and dewatering of slurries.

## Applications

- Dewatering of starches
- Filtration of glucose
- Filtration of fruit juice
- Dewatering of modified starches

## Process description

The drum surface is divided in cells. By means of a mechanical device in the suction head, sections of the drum can be cut off from vacuum while other sections can be pressurized.

Product is sucked on to the filter drum surface. The fluid and air pass the filter medium, enter the suction pipes inside the drum and are discharged through the suction header into the filtrate separator. The solids remain on the filter medium and are discharged.

FC vacuum filters are provided with an agitator, cake discharge system, drum cleaning spray pipe and filtrate separator with level control.

FC filters can be provided with a wide range of cake discharge systems, a blowback system and a cake washing system. SiccaDania vacuum filters are made of stainless steel.

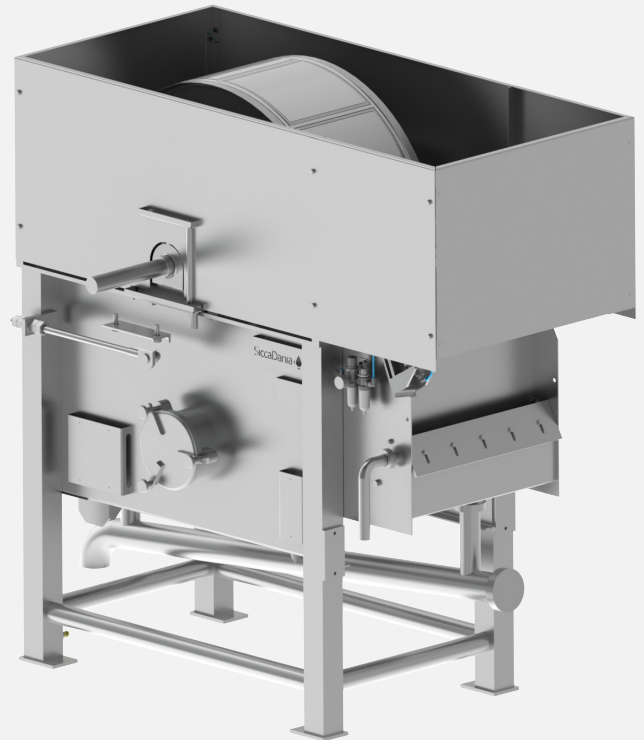

## Benefits of the vacuum filter FC-series

- High efficiency
- Long operational life
- Minimal maintenance
- Wear resistant

## Technical data

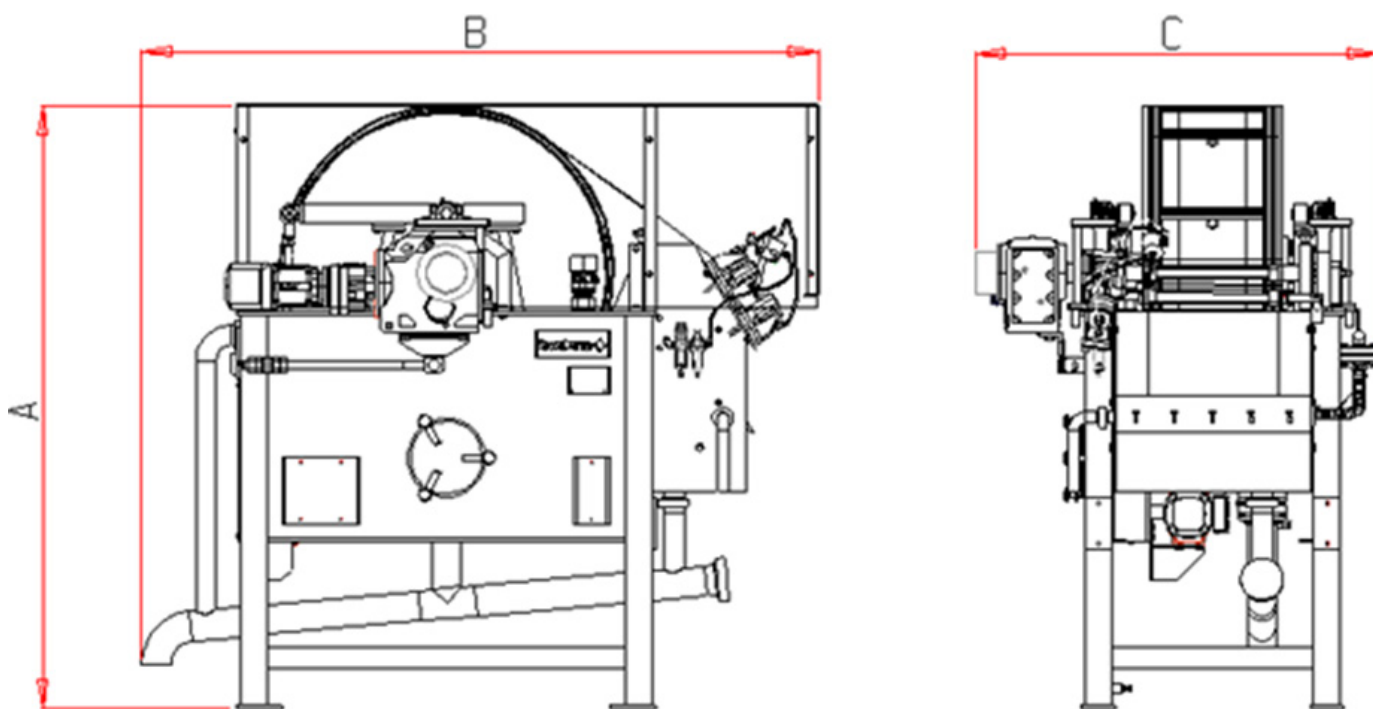

Model	FC100-1*	FC100-2*	FC100-3.15*	FC100-4*	FCX**
A (mm)	1800	1800	1800	1800	X
B (mm)	2030	2070	2150	2160	X
C (mm)	1210	1530	1950	2170	X

\* Indicates screen area

\*\* Possibility for customised design. Contact our experts for more information

Data*	FC100-1	FC100-2	FC100-3.15	FC100-4	FCX
Capacity (m <sup>3</sup> /h)	200	400	630	800	X

Approx. values based on native potato starch kg/h @ 100% DS

## Design

### Standard design

- High efficiency
- Sanitary construction
- Low energy consumption

### Options

- Scraper knife discharge
- Belt discharge
- Fleece discharge
- String discharge
- Roll discharge
- Blow-back system
- Cake washing system
- Turn-key installation with pumps etc.