

Refining sieve R-series

ABOUT THE REFINING SIEVES

The SiccaDania refining sieve is developed for the separation of solids from process fluids. Equipped with an effective and fully automatic drum cleaning system, it is especially suitable for separating fibres from fluids.

SiccaDania supplies the refining sieves in different sizes to fit any capacity up to about 150 m³ per hour. The refining sieve which is characterised by a simple and robust construction, is maintenance friendly.

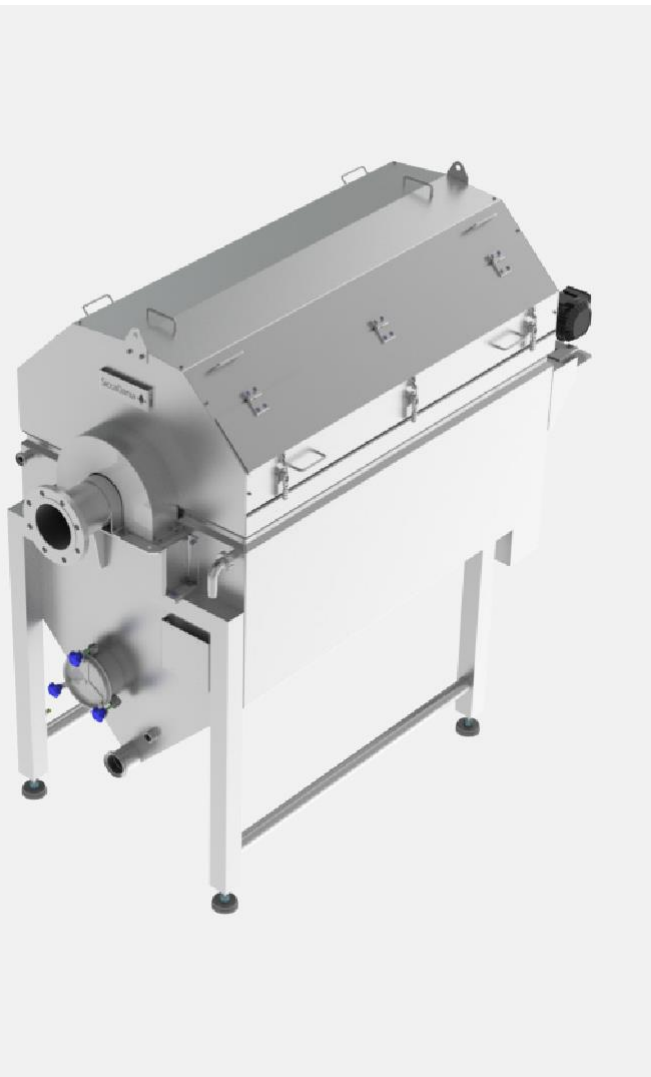

Specifications

Fluid with coarse particles and fines enter the sieve drum. The fluid leaves the drum through the sieve lining and is collected in the buffer tank underneath.

Solids are pushed along to the far end of the drum by means of a ribbon screw. In this action it is further dewatered. Finally, the solids leave the sieve-drum through the solids outlet.

Equipment

The refining sieve is equipped with a drum frame with integrated ribbon screw. The frame is lined with sieve material. The simple fastening system warrants quick exchange during maintenance.

A drum cleaning spray pipe operated by means of a timer controlled valve prevents the lining from plugging.

Optimal tailor made design

- Robust construction
- Sustainable & long durability
- Quick replacement of the lining
- Enclosed leakage-free process
- Maintenance friendly
- Effective drum cleaning system
- Continuous & smooth operation

Applications

- French fries and potato chips industry
- Starch and flour industry
- Pulp and paper industry
- Vegetable and fruit processing industry
- Waste processing industry
- Chemical industry

Technical data

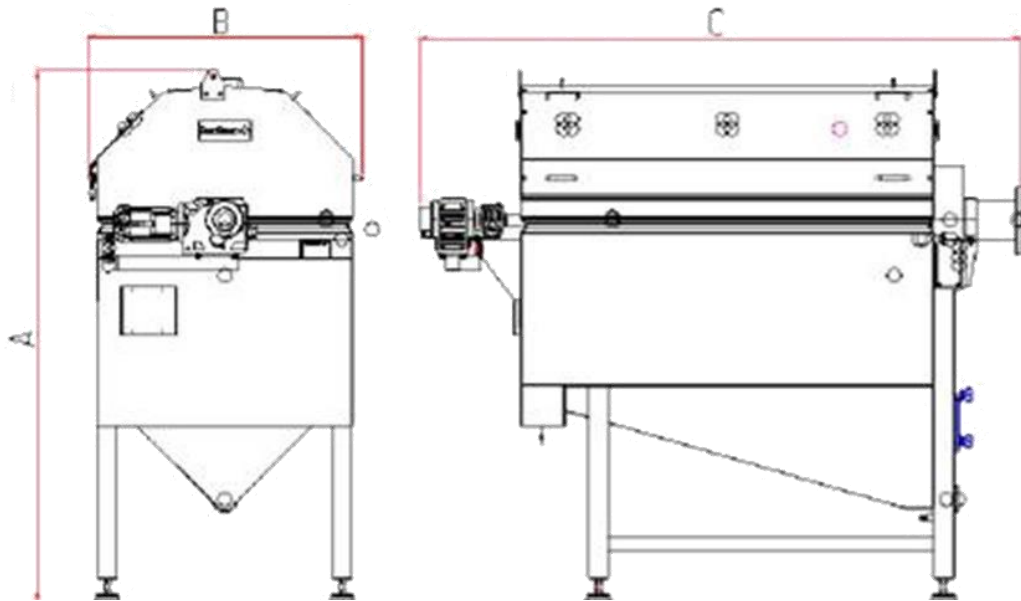

Model	R80-100*	R80-150*	R80-200*	R125-250*
A (mm)	2180	2180	2180	2390
B (mm)	1140	1140	1140	1560
C (mm)	1960	2490	2860	3780

* Indicates sieve size

Data*	R80-100	R80-150	R80-200	R125-250
Capacity (m ³ /h)	30	50	90	150
Screen surface (m ²)	2.5	3.75	5	9.8
Motor (kW)	0.75	0.75	0.75	1.1

Approx. values based on 500 µm screens, water containing 1% coarse